

Ambrogio Twenty 25 RTK

MD-CO-RO-43- Rev.1.1 - 30/10/2025 - Ambrogio Twenty 25 RTK

Spare Parts Catalogue

Previous Revision 1.0
Current Revision 1.1
From 2025-10

Models Type Included

E025ER0

Twenty 25 RTK

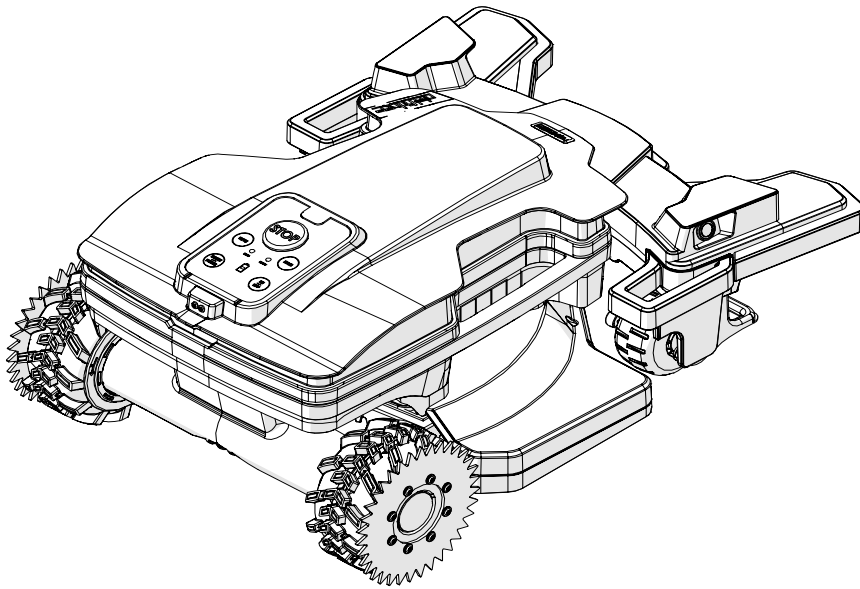

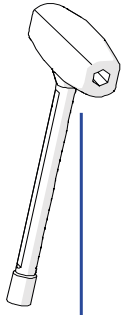

1

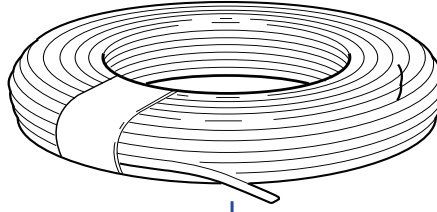

2

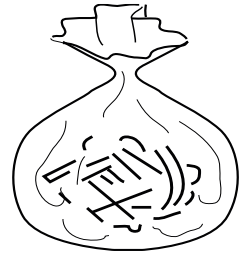

3

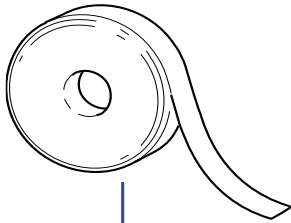

4

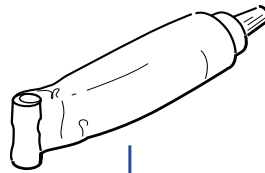

5

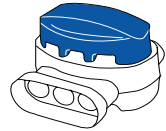

6

Tav. **01** | **0**
 Tab.
 Taf.

Rif.	Code	Qt.in Robot		(IT) Descrizione * (GB) Description	MOQ
1	015Z13700A	1		Cacciavite - Screw Driver	1
2	CS_E025_1	1	MT 100 (1x0.75)	Cavo - Cable	1
2	CS_E025_15	0-1	MT 150 (1x0.75)	Cavo - Cable	1
3	200A00100A	1	(100 Pz)	Conf. Chiodi - Nails Bag	1
3	200A00200A	0-1	(200 Pz)	Conf. Chiodi - Nails Bag	1
4	CS_C0111	0		Nastro Agglomerante - Stretch Electrical Tape	1
5	CS_C0109	0	200 Gr	Grasso - Grease	1
6	200A00003	1		(3pcs) - Connettore - Connector	1
6	200A00001	0		(10pcs) - Connettore - Connector	1
6	200A00050	0		(50pcs) - Connettore - Connector	1

Solo per rivenditori
 Only for dealer

Code	(IT) Descrizione * (GB) Description	MOQ
CS_BT_USB	Convertitore USB-Bluetooth - USB-Bluetooth Converter	1



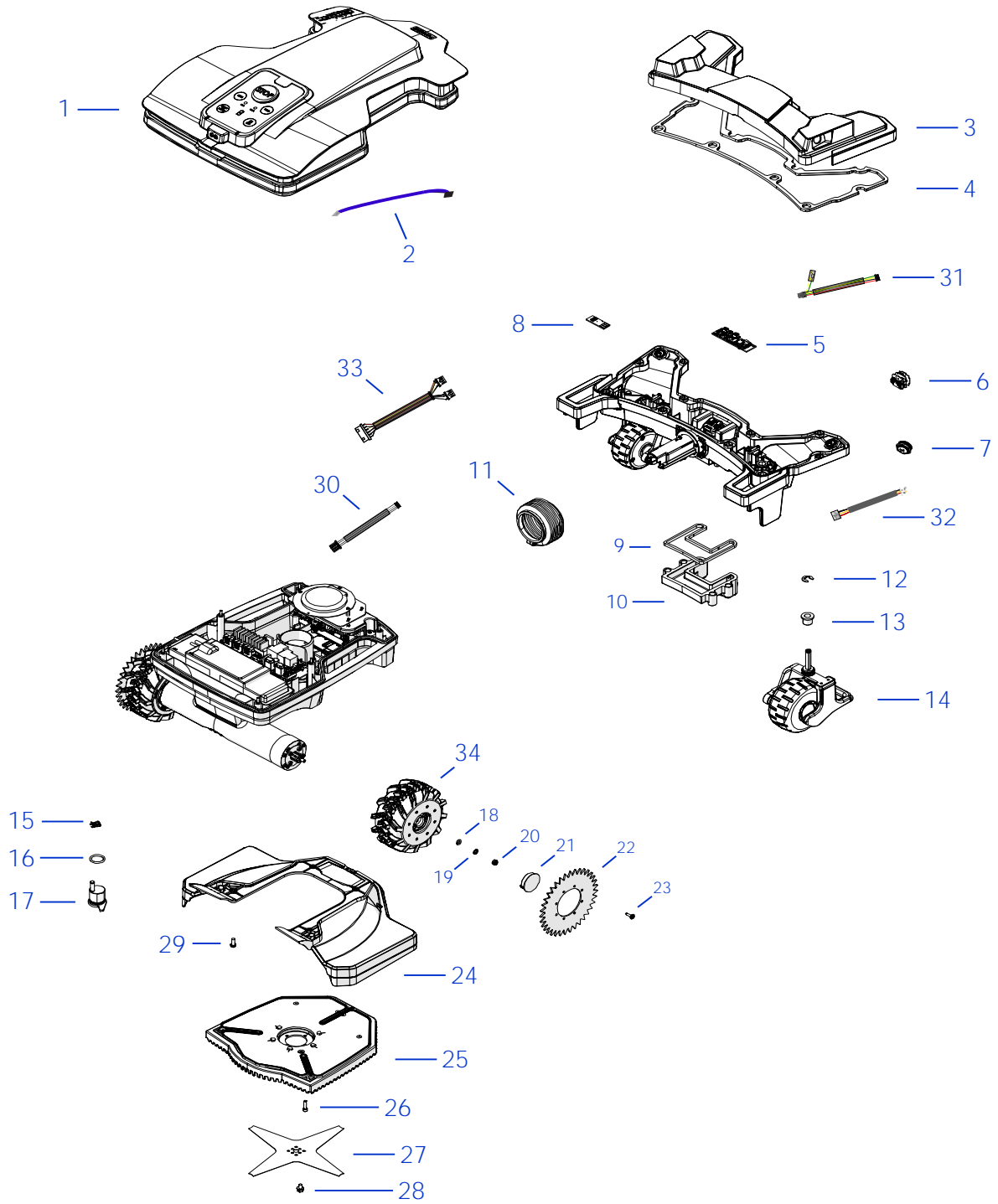

Rif.	Code	Qt.in Robo t		(IT) Descrizione * (GB) Description	MOQ
1	L25Z00370A_R	1	Ambrogio	Assieme calotta - Cap set	1
2	CB13_L400.1	1		Cablaggio sensorer pioggia - Rain sensor cabling	1
3	L25Z00640B_R	1		Coperchio bumper - Bumper cover	1
4	L25Z00613B_R	1		Guarnizione bumper - Bumper gasket	1
5	075E03001A	1		Modulo HUB - HUB Module board	1
6	075Z54700A_R	1		PCB Radar - PCB Radar	1
7	075Z95421A	6		Sensore USS - USS Sensor	1
8	L25E00400A	1		Sensore sollevamento - Lift sensor	1
9	L20Z16500A	1		Guarnizione - Gasket	10
10	L20Z10800B_R	1		Contatti ricarica - Charging plates	1
11	L25Z07200A	1		Soffietto - Bellow	1
12	C02268	2		Seger - Seger	10
13	C02701	4		Boccola - Bushing	1
14	L25Z00381A_R	1	Left	Assieme ruota anteriore - Front wheel assembly	1
14	L25Z00409A_R	1	Right	Assieme ruota anteriore - Front wheel assembly	1
15	C01936	1		Seger - Seger	10
16	C01440	1		Guarnizione - Gasket	10
17	L20Z06500A	2		Eccentrico - Eccentric	1
18	C02349	2		Rosetta - Flat washer	10
19	C00128	2		Rosetta dentellata - Toothed washer	10
20	C02223	2		Dado - Nuts	10
21	015Z06700A	2		Coperchio ruote - Wheel cap	1
22	L25Z00021A	1		Kit arpione - Harpoon kit	1
23	C02231	16		Vite - Screw	10
24	L25Z00621A_R	1		Paralame esterno - External Blade guard	1
25	L25Z07800A_R	1		Paralame interno - Internal blade guard	1
26	C02222	4		Vite metrica - Metric screw	10
27	075Z07800A_R	1		Lama - Blade	1
28	C02650	4		Vite - Screw	10
29	C03080	4		Vite - Screw	10
30	015CB03.02	1		Cablaggio Radar_CPU - Radar to CPU cabling	1
31	015CB06.01	1		Cablaggio modulo HUB - HUB Module cabling	1
32	025CB03.01	2		Cablaggio USS-HUB - USS-HUB cabling	1
33	025CB04.01	1		Cablaggio scheda urto - Bump board cabling	1
34	L25Z00414A_R	1	Sx	Ruota posteriore - Rear wheel	1
34	L25Z00411A_R	1	Dx	Ruota posteriore - Rear wheel	1

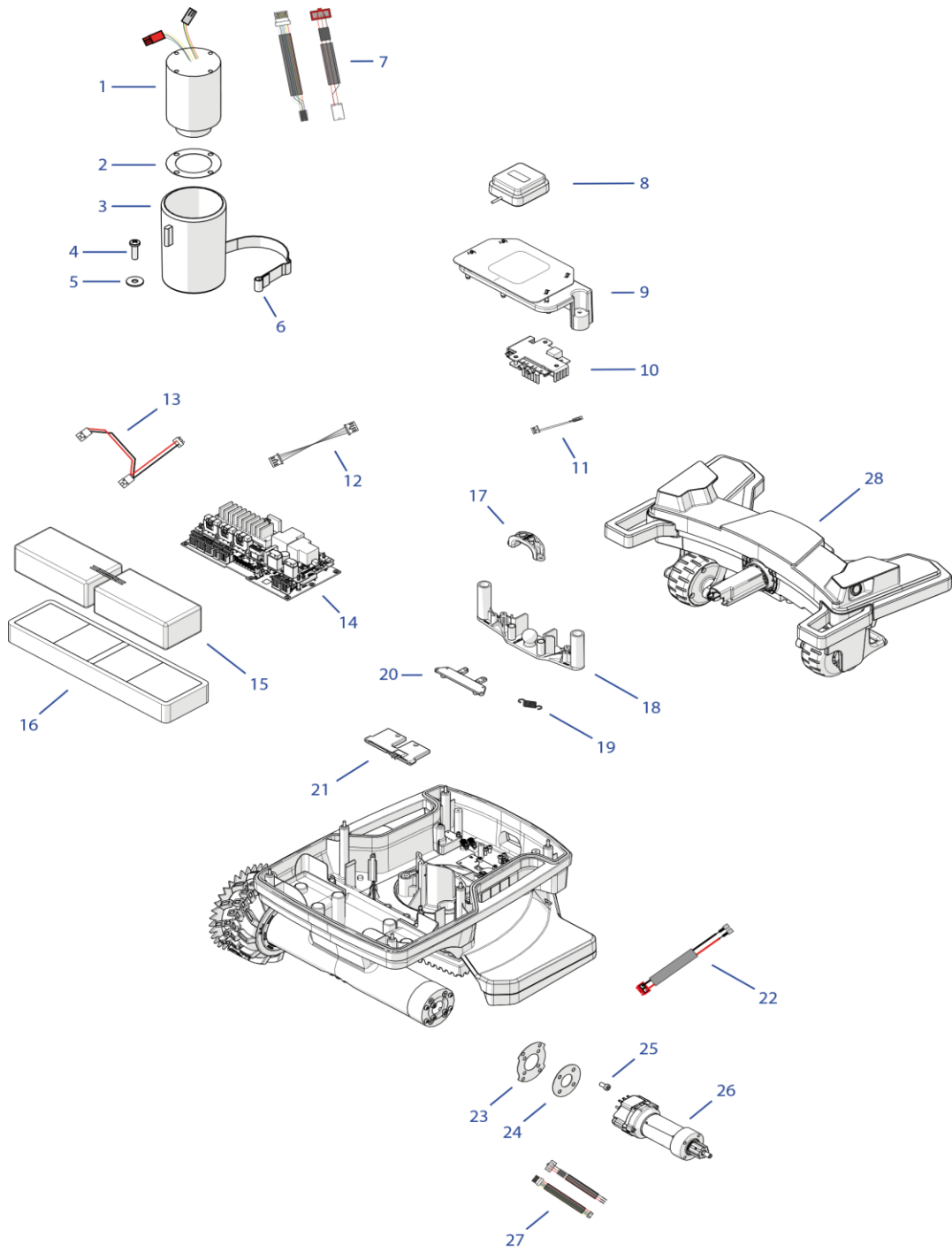

Rif.	Code	Qt.in Robo t		(IT) Descrizione * (GB) Description	MOQ
1	C02362_25_R	1	Brushless	Motore di taglio - Blade motor	1
2	015Z13400A	1		Guarnizione - Gasket	10
3	015Z03600B_R	1		Tubo motore lama - Motor blade support	1
4	C00691	1		Vite - Screw	10
5	C00026	1		Rondella - Washer	10
6	015Z07300B	1		Molla - Spring	1
7	051CB04.01	1		Adattatore cablaggio motore - Motor cabling adapter	1
8	400Z95477A_R	1		Antenna RTK - RTK Antenna	1
9	L25Z00361A_R	1		Supporto modulo RTK - RTK module support	1
10	042Z95654A_R	1		Modulo Connect RTK - RTK Connect module	1
11	110E01100A	1		Cablaggio Terminazione CAN - CAN termination cable	1
12	CB09_CONNECT	1		Cablaggio - Wiring	1
13	050CB01.01	1		Cablaggio batteria - Battery cable	1
14	015E00400A_R	1		Scheda madre - Mainboard	1
15	075Z60900A_R	2		Batteria - Battery	1
16	L25Z08100A	1		Supporto batteria - Battery support	1
17	L25Z00098B	1		Rinforzo bumper - Bumper reinforcement	1
18	015Z04600B	2		Supporto gruppo urto - Bump group support	1
19	L25Z00019A_R	2		Kit bumper - Bumper kit	1
20	L25Z00694A_R	1		Supporto magnete - Magnet support	1
21	L25Z00646A_R	1		Scheda urto - Bump board	1
22	025CB01.02	1		Cablaggio ricarica - Recharging cable	1
23	L25Z00662A_R	2		Guarnizione - Gasket	1
24	L25Z00132A_R	2		Guarnizione - Gasket	1
25	C02984	8		Vite - Screw	10
26	L25Z10026A_R	2		Motore ruota - Wheel motor	1
27	CB01_MRB_V02	2		Cablaggio Motore - Motor Cabling	1

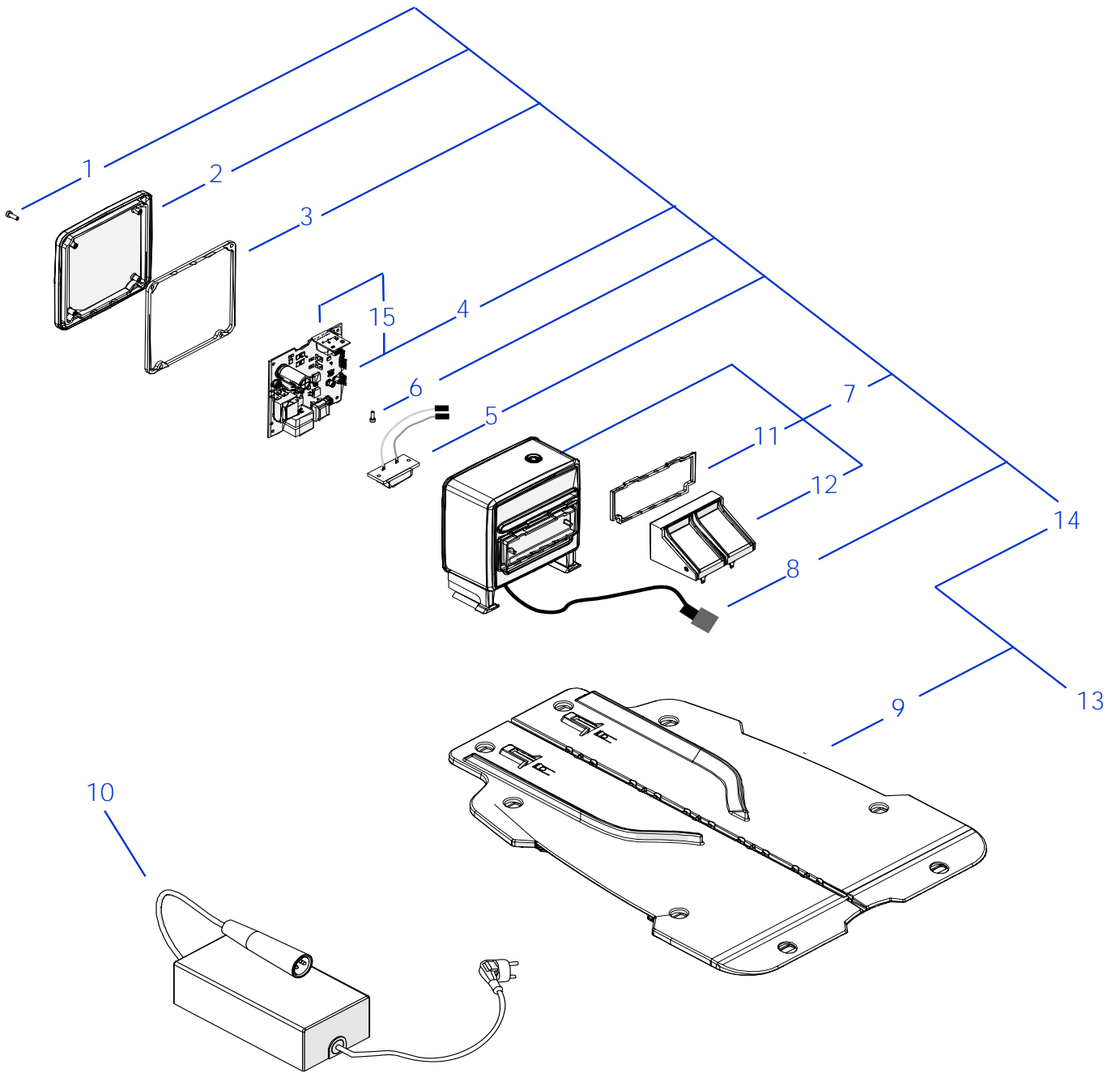

Rif.	Code	Qt.in Robo t		(IT) Descrizione * (GB) Description	MOQ
1	C02188	4	M4 x 12	Vite - Screw	8
2	015Z08700A	1		Coperchio torretta - Turret box	1
3	015Z08900A	1		Guarnizione torretta - Turret gasket	10
4	015E00700A_R	1		Trasmettitore - Transmitter	1
5	A222522	1		Connettore - Connector	1
6	C00364	2	M3 x 10	Vite - Screw	10
7	L20Z22559A_R	1		Box trasmettitore - Transmitter box	1
8	042CHS01.04	1		Cablaggio base ricarica - Docking station wiring	1
9	L25Z05500A_R	1		Pianale - Floor	1
10	C02311	1		Alimentatore - Power supply	1
11	L20Z04400A	1		Guarnizione - Gasket	10
12	L20Z22549A	1		Contatti ricarica - Recharge contacts	1
13	L25Z08800B_R	1		Base completa - Complete base	1
14	015Z10400B_R	1		Torretta completa - Transmitter box assembly	1
15	015A00700A	1		Scheda LED trasmettitore - LED transmitter board	1